

# BRISTAN

## Capri Tap Range

### Installation Instructions & User Guide



Please keep these instructions for future reference and request of replacement parts

Thank you for choosing Bristan, the UK's leading taps and showers expert. We have designed these products with your enjoyment in mind. To ensure that they work to their full potential, they need to be fitted correctly. These fitting instructions have been created to give you all of the information you need and, if you need any further help, please do not hesitate to give us a call on 0844 701 6273.

<b>Contents</b>	<b>Page</b>
1. Important Safety Information	03
2. Specification	03
3. Dimensions	04
4. Installation Requirements & Notes	05
5. Installation	06-09
Basin & Bath Taps	06
Basin Mixer (without waste)	06
Basin Mixer, Eco Basin Mixer	07
Bidet Mixer	08
Bath Filler & Bath Shower Mixer	09
6. Maintenance	10
7. Guarantee & Service Policy	11

## 1. Important Safety Information

Please read these instructions thoroughly and retain for future use. All products manufactured and supplied by Bristan are safe provided they are installed correctly, used correctly and receive regular maintenance in accordance with these instructions. If you are in any doubt about your ability to install these products safely you must employ the services of an experienced plumber.

 Before starting any installation please consider the following: Prior to drilling into walls, check that there are no hidden electrical wires, cables or water supply pipes. This can be checked with the aid of an electronic detector.

- If power tools are used do not forget to:
  - Wear eye protection
  - Unplug equipment after use

**Bath Shower Mixer only** – Do not use if the showerhead or shower hose has been damaged or is blocked. Do not crush or kink the shower hose, This could damage the hose and cause leaks. These products **must not** be modified in any way as this will invalidate the guarantee.

These fittings need to be installed in accordance with and meet the requirements of the Water Supply (Water Fittings) Regulations 1999 and Scottish Byelaws 2004.

## 2. Specification

Operating pressure range (bar)	Min	Max.
Basin Taps	0.2	8.0
Bath Taps	0.3	8.0
Basin Mixer	0.3	5.0
Bidet Mixer	0.2	8.0
Bath Filler	0.2	8.0
Bath Shower Mixer	0.3	8.0

Maximum static pressure – 10.0 bar

NOTE:- Nominally equal (balanced) inlet supply pressures are recommended for optimum performance.

Designed to comply with BS EN 200 for single taps/ combination taps for water systems of type 1 and 2 general technical specifications and to be used within systems designed to BS 6700.

BS 6700 recommends the temperature of stored water should never exceed 65°C. A stored water temperature of 60°C is considered sufficient to meet all nominal requirements and will minimise the build up of lime scale in hard water areas.

# BRISTAN

## 3. Dimensions

Basin Taps

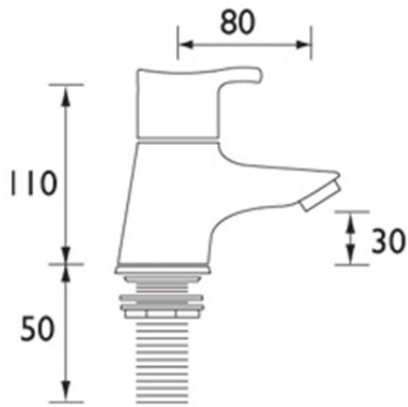

Bath Taps

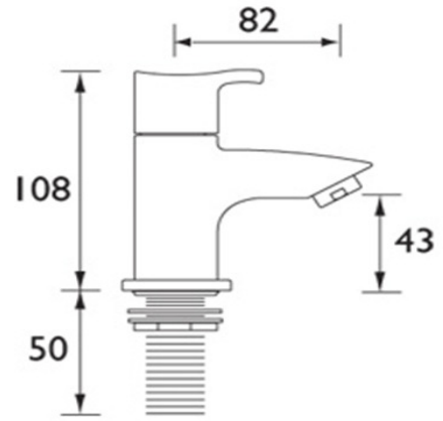

Basin Mixer

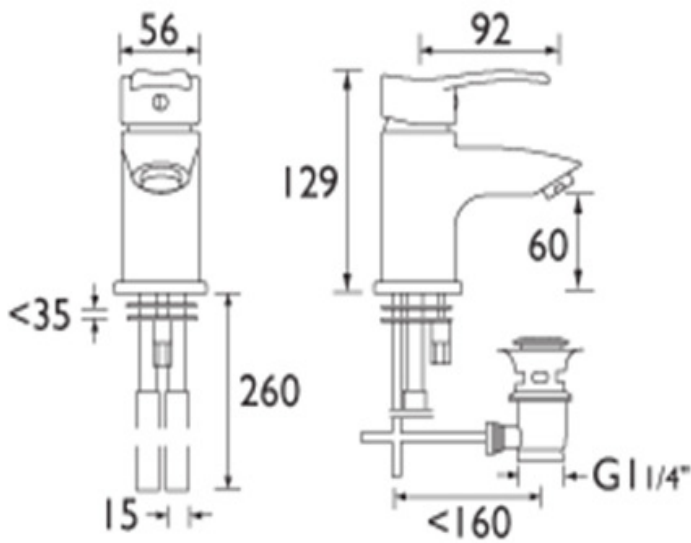

Bidet Mixer

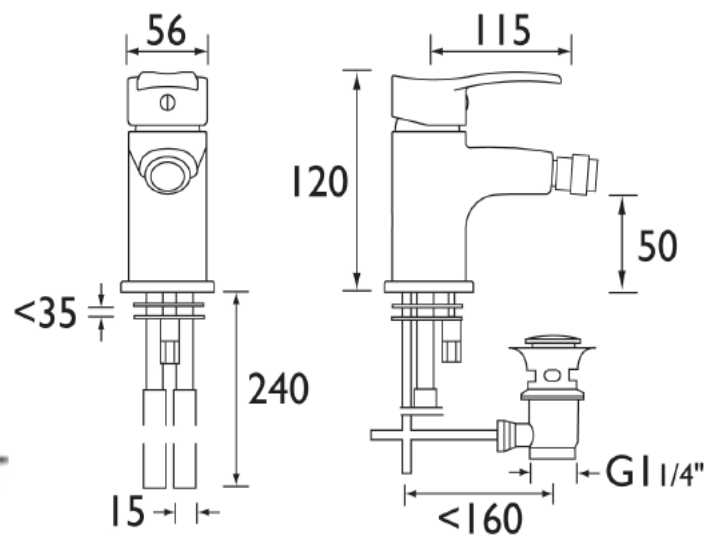

Bath Filler

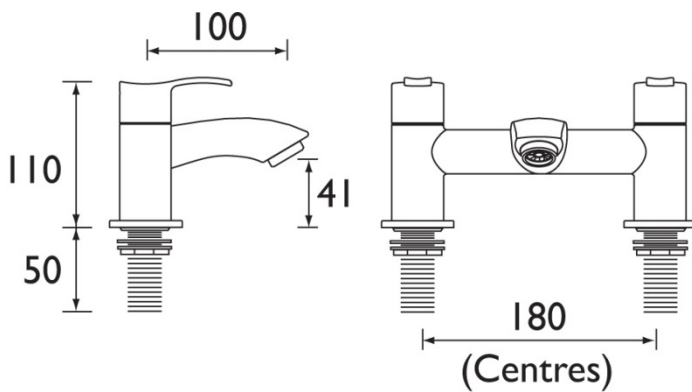

Bath Shower Mixer

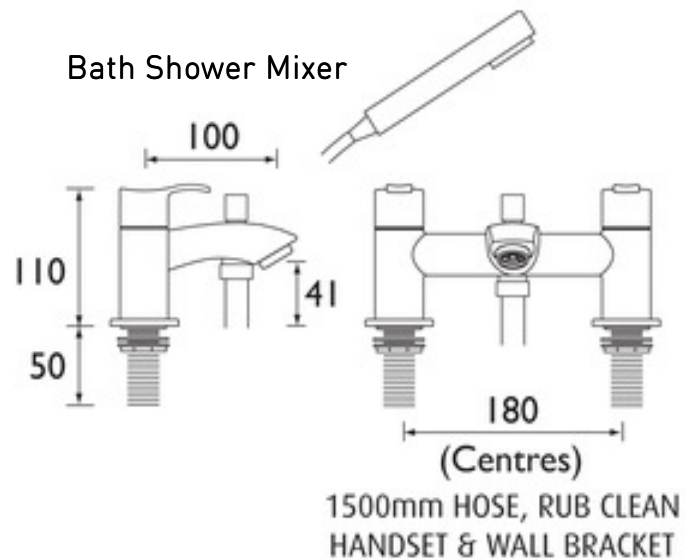

## 4. Installation Requirements & Notes

These fittings need to be installed in accordance with the following Installation Requirements and Notes (IRN) to ensure they meet the requirements of the Water Supply (Water Fittings) Regulations 1999 and the Scottish Byelaws 2004.

**IRN R001:** See text of entry for Installation Requirements or Notes.

**IRN R006:** This tap or combination tap assembly has a Type AUK3 air gap and is therefore for installation in any premises to protect against a backflow risk up to a Fluid Category 5.

**IRN R010: - Schedule 2-15 (1) :** Water supplies shall be a reasonably balanced pressures from a common source (e.g. hot and cold supplies both from the same storage or both from a supply pipe). Where the fitting is supplied from unbalanced supplies (e.g. hot and cold supplies from separate sources) a **'Listed' single check valve** or some other no less effective backflow prevention device shall be fitted immediately upstream of both hot and cold water inlets.

**IRN R040: - Schedule 2-15 (1):** The fitting shall be installed so that its outlet discharges above the spill-over level of any fixed appliance as indicated below:-

**For backflow protection in domestic or installations up to, and including, Fluid Category 3.**

If the fitting cannot be installed as indicated in the table opposite it shall be installed as either **a** or **b** below:

**a:** with an approved double check valve assembly or some other no less effective backflow prevention device immediately upstream of the inlet.

**b:** so that it draws water by gravity only from a cistern, or cylinder having a permanently open vent pipe, and the distributing pipe supplies no other fitting (other than draining tap) at a lower level.

**For backflow protection in premises or installations up to, and including Fluid Category 5.**

The vertical distance of the outlet above the spill-over level shall be not less than 20mm or twice the diameter of the inlet pipe to the fitting, which ever is the greater. If the fitting cannot be installed as indicated it shall be installed with a backflow prevention arrangement suitable for the Fluid Category.

Size of tap or combination fitting.	Vertical distance of outlet above spill-over level.
1. Not exceeding 1/2 in	20mm
2. Exceeding 1/2 in but not exceeding 3/4 in	25mm
3. Exceeding 3/4 in	70mm

## 5. Installation

### Basin Taps & Bath Taps

1. Identify all components are present prior to installation.
2. Install the taps (5) to the basin/bath. The backnut (1) and backnut washer (2) are used under the basin/bath to secure the taps to the surfaces of basin/bath with the washer (3) and the plinth (4) above.
3. Connect the hot and cold water supplies.
4. Turn on the water supplies. Open both taps, letting the water flow for a few minutes to check all joints and connections for leaks.

**Note:** Bath taps operate at a minimum pressure of 0.3 bar (3 metre head).

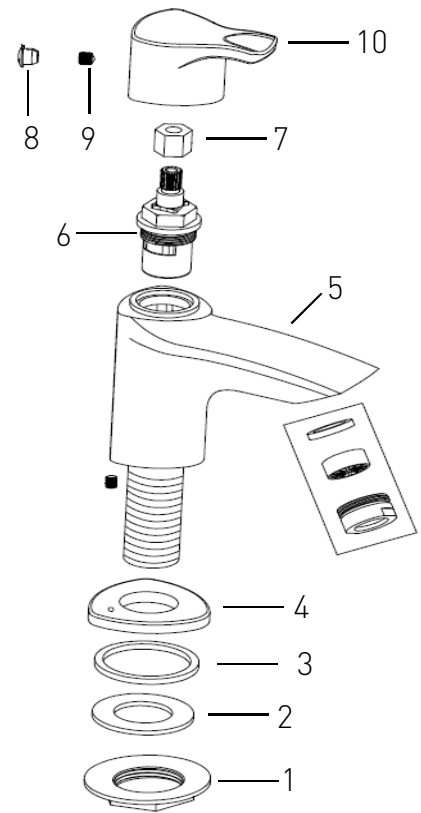

### Basin Mixer-without waste

1. Identify all components are present prior to installation.
2. Install the mixer (7) to the basin. Secure the mixer to the surface of basin using the fixing kit (10) with plinth washer (9) and plinth (8) above the basin.
3. Screw in flexible connecting pipes (11) to the mixer by HAND ONLY (DO NOT OVERTIGHTEN), and then connect hot and cold water supplies.
4. Turn on both water supplies. Lift and turn the handle both ways for a few minutes, letting the water flow, to check all joints and connections for leaks.

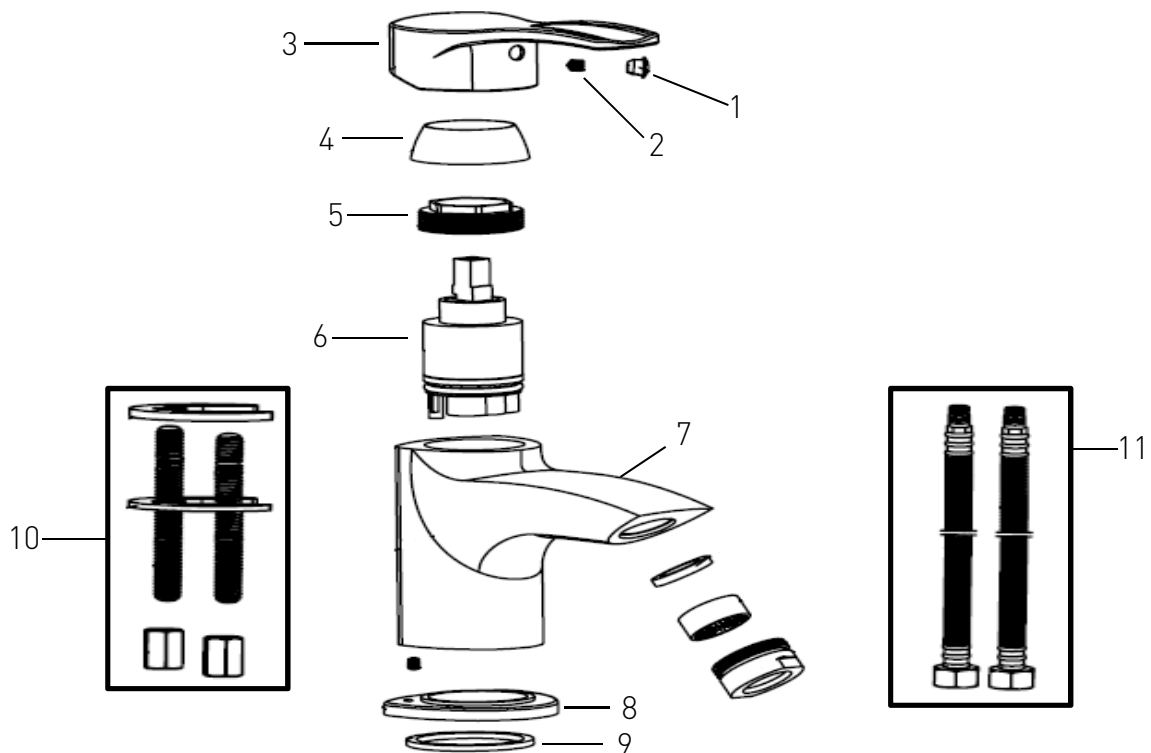

## 5. Installation cont.

### Basin Mixer, Eco Basin Mixer

1. Identify all components are present prior to installation.
2. Install the mixer (7) to the basin. Secure the mixer to the surface of basin using the fixing kit (10) with plinth washer (9) and plinth (8) above the basin.
3. Screw in flexible connecting pipes (11) to the mixer by **HAND ONLY (DO NOT OVERTIGHTEN)**, and then connect hot and cold water supplies.
4. Fit the pop-up waste (12), with the flat washer below and the shaped washer above the basin. It is advised that a silicon sealant be applied to both sealing faces of the washers. The plug height can be set by adjusting the waste rod operating rod, rod connector and then screw in the base of the plug. Friction for the waste mechanism can be adjusted using the waste cap.(DO NOT OVERTIGHTEN).
5. Turn on both water supplies. Lift and turn the handle both ways for a few minutes, letting the water flow, to check all joints and connections for leaks.

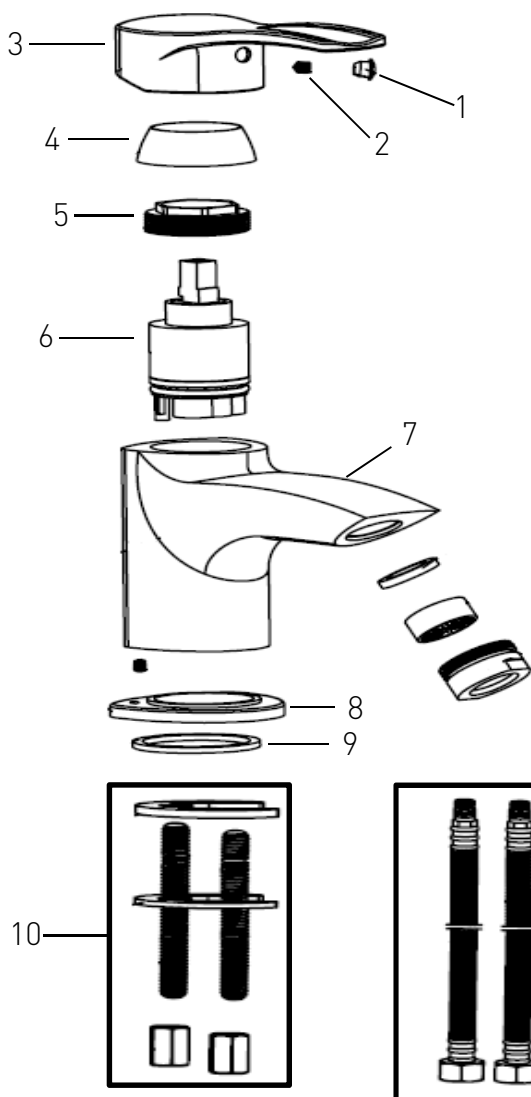

NOTE: CAP EBAS C has a click position to encourage the use of less water. For increased flow, the Eco Click feature can be overridden.

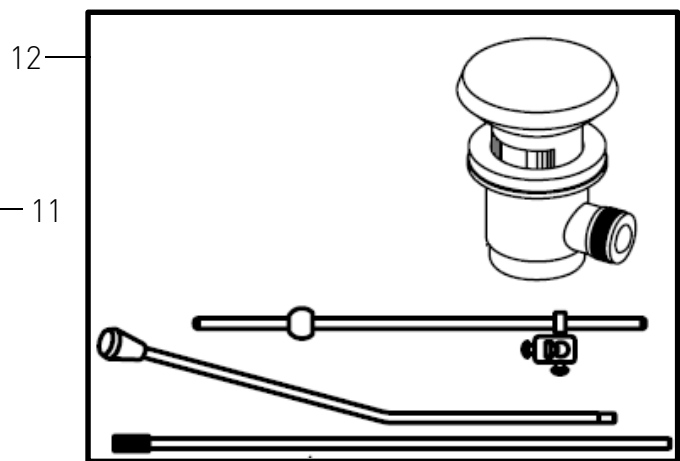

## 5. Installation cont.

### Bidet Mixer

1. Identify all components are present prior to installation.
2. Install the mixer (6) to the bidet. Secure the mixer to the surface of bidet using the fixing kit (9) with plinth washer (8) and plinth (7) above the bidet.
3. Screw in connecting copper tail pipes (10) to the mixer by HAND ONLY (DO NOT OVERTIGHTEN), and then connect hot and cold water supplies.
4. Fit the pop-up waste (11), with the flat washer below and the shaped washer above the bidet. It is advised that a silicon sealant be applied to both sealing faces of the washers. The plug height can be set by adjusting the waste rod operating rod, rod connector and then screw in the base of the plug. Friction for the waste mechanism can be adjusted using the waste cap (DO NOT OVERTIGHTEN).
5. Turn on the water supplies. Lift and turn handle both ways for a few minutes, letting the water flow, to check all joints and connections for leaks.

**NOTE:** The Bidet Mixer is fitted with a directional nozzle.

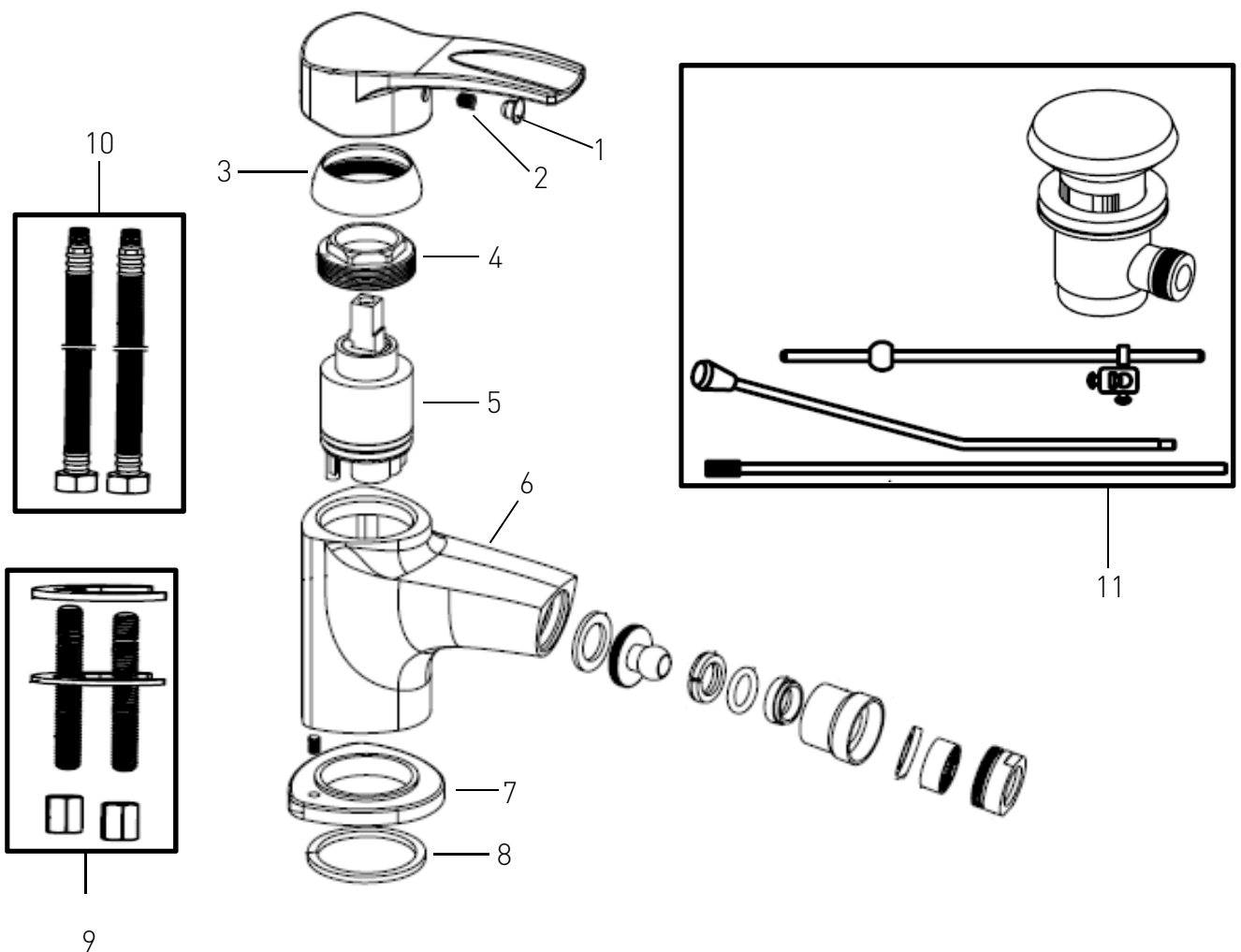



## 5. Installation cont.

### Bath Filler & Bath Shower Mixer

1. Identify all components are present prior to installation.
2. Install the mixer body (5) to the bath using the backnuts (1) and backnut washers (2) provided under the bath with the plinth (4) and washer (3) above.
3. FOR BATH SHOWER MIXER ONLY: Fit the hose to the mixer (5) underneath the spout to diverter (11). Fix the wall bracket to the wall ensuring that the handset and hose will reach it.
4. Connect the hot and cold water supplies and turn water supplies on.
5. Fully open the valves (6) by turning handles (10), letting it run for a few minutes to check for leaks.
6. FOR BATH SHOWER MIXER ONLY: Operate the mixer in both bath and shower mode. To switch from bath to shower mode, pull the diverter knob (11) up. After use, the mixer automatically reverts to the bath filling mode.

**Note:** The Bath Shower Mixer operates at a minimum of 0.3bar (3 metre head).

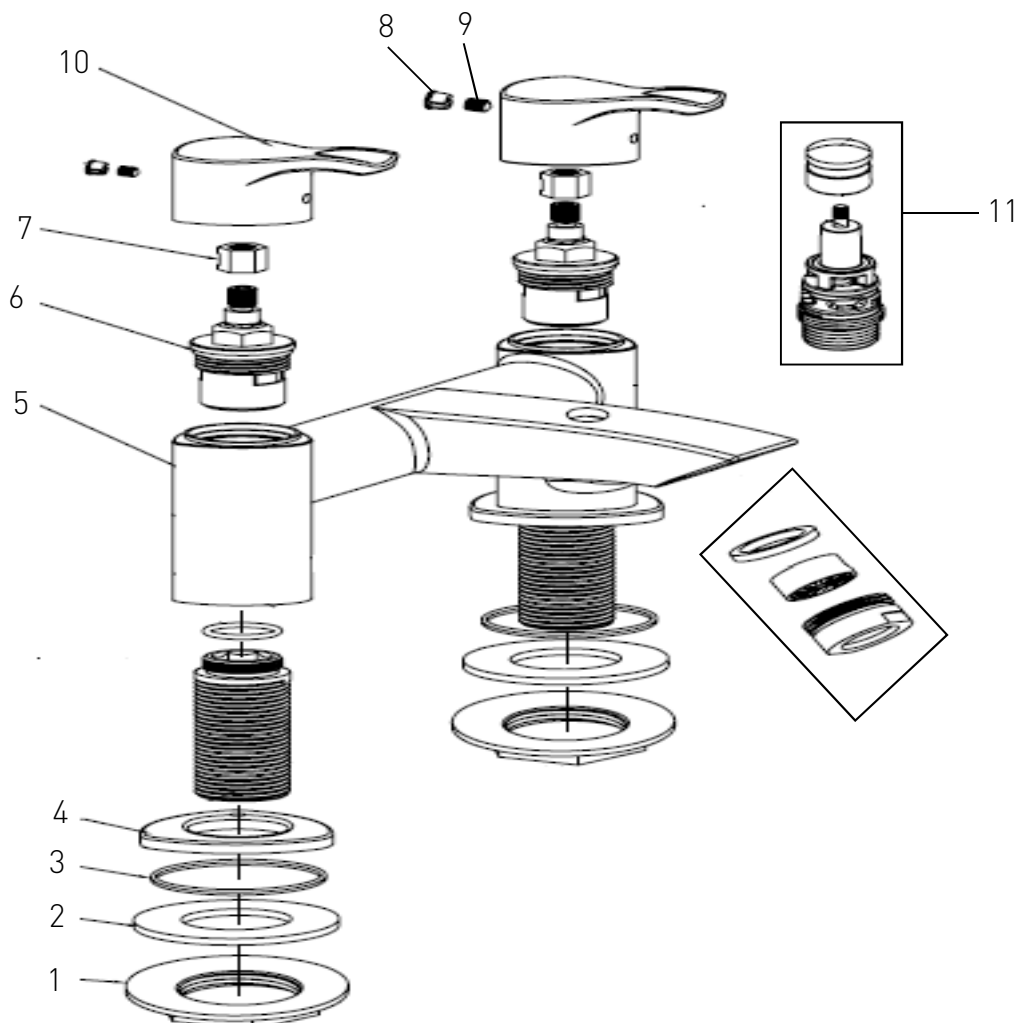

## 6. Maintenance

### General Cleaning

Your fitting has a high quality finish and should be treated with care to preserve the visible surfaces. All finishes will wear if not cleaned correctly. The only safe way to clean your product is to wipe with a soft damp cloth. Stains can be removed using washing up liquid. All bathroom cleaning products (powders and liquids) will damage the surface of your fitting, even the non-scratch cleaners.

**Note:** Never use abrasive detergents or disinfectants or those containing alcohol, hydrochloric acid or phosphoric acid.

### Maintenance

If your fitting begins to leak the following should be carried out;

1. Remove the handle by prising out the cap and then loosening the screw. Pull the handle from the spline of the valve / cartridge.
2. Remove the valve from the body by unscrewing it, If cartridge – unscrew the cartridge retaining nut and then pull the cartridge from the body.
3. Clean the washer and seating and replace valve / cartridge if necessary.
4. replace the valve / cartridge

**Note:** The cartridge has locating pins on the underside which fit into holes in the body.

4. Replace the handle, tighten the screw and push the cap back in.

If the problem persists please contact our customer services department quoting the product code.



Bristan recommend E-cloth for cleaning all of our bathroom & kitchen products. Using just water, E-cloth gives a smear free, deep clean by breaking up and hold dirt, which normal cloths leave behind. Order through your Bristan stockist (order code: ECLOTH).



**Guarantee**

## 7. Guarantee

Bristan offers solid guarantees to provide you with complete peace of mind.

### Taps and Mixers

5 year parts and 1 year labour\*. Gold, painted and special finishes 3 years parts only.

All subject to proof of purchase.

### Mixer Shower Valves

5 year parts. 5 year labour\* (subject to registration), or 1 year with proof of purchase.

Gold, painted and special finishes 3 years parts only.

### Pumps and Power Showers

2 year parts. 1 year labour\* (subject to registration).

### Electric Showers/Instantaneous Water Heaters

2 year parts. 1 year labour\* (subject to registration).

### Accessories

5 year parts only. Includes bathrooms accessories, shower accessories (e.g. hoses, handsets and poles), wastes, WC levers and light pulls. Gold, painted and special finishes 3 years parts only.

### Sanitaryware

5 year parts only. Subject to proof of purchase.

### Shower Enclosures and Shower Trays

10 year parts (subject to registration), or 2 years with proof of purchase. 1 year labour\* (subject to registration), or 1 year with proof of purchase.

### Heated Towel Rails

5 year parts only. Gold, painted and special finishes 3 years parts only. All subject to proof of purchase.

\*Labour provided by an approved Bristan engineer. Guarantee only applies to products with a manufacturing fault. A deferred payment will be necessary in order to secure any visits by our engineers which will be charged if the problem is found **not** to be a manufacturing fault. If the fault is found to be down to a manufacturing error, the payment will be released and not charged.

This guarantee applies to products purchased within the United Kingdom or Republic of Ireland, but does not apply to products used commercially.

The guarantee is only available to original purchasers who have proof of purchase.

The installation must allow ready access to all products for the purpose of inspection, maintenance or replacement.

Any part found to be defective during the above guarantee period will be replaced without charge, providing that the product has been installed in accordance with the instructions, used as intended, and regularly serviced.

Servicing should be carried out at regular intervals of no more than 12 months and more frequently in hard water areas (heavy lime scale) areas.

In the unlikely event that any problems are encountered with the product's performance on installation, you must obtain guidance/authorisation from our Customer Service Department, and be able to supply proof and date of purchase, before any remedial action is taken.

The guarantee excludes general wear and tear and damage caused by accident, misuse or neglect, and does not cover the following:

- Components that are subject to general wear and tear such as filters, seals, 'O' rings and washers etc.
- Damage caused by faulty installation
- Damage caused by lime scale or any waterborne debris
- Damage caused by inappropriate cleaning products (see user instructions)
- Damage caused by the use of non-Bristan parts
- The product being used for a purpose other than intended by the manufacturer.

In the interests of continuous product improvement Bristan reserves the right to alter specification as necessary.

If your product is out of its guarantee period, or you would like to extend the guarantee, then please see our [extended warranty offer](#).



# BRISTAN

This booklet covers all product codes  
CAP ½ C, CAP ¾ C, CAP BAS C, CAP BASNW C,  
CAP EBAS C, CAP BID C, CAP BF C, CAP BSM C

**Helpline**

**0844 701 6273**

Bristan Group Limited  
Birch Coppice Business Park, Dordon, Tamworth, B78 1SG

A Masco Company  
Website: [www.bristan.com](http://www.bristan.com)  
Telephone: 0844 7016 274      Facsimile: 0844 701 6275  
Email: [enquire@bristan.com](mailto:enquire@bristan.com)